

Implementation of an Efficient Ripple Carry Adder by Low Power Techniques for Ultra Applications

S. Sindhuri¹, R. Sravani², S. Rambabu³

Dept of ECE, SREC, Nandyal.

Dept of ECE, SREC, NANDYAL

Asst professor, SREC, Nandyal

ABSTRACT

The main goal of this paper is to provide new low power solutions for very large scale integration. Designers especially focus on the reduction of the power dissipation which shows increasing growth with the scaling down of the technologies. In this paper various technologies at the different levels of the design process have been implemented to reduce the power dissipation at the circuit, architecture and system levels. Previous technologies are summarized and compared with our new approach is presented in this paper.

The main objective of this project is the reduction of power dissipation by eliminating the PMOS tree and also by utilizing energy stored at the output can be retrieved by the reversing the current source direction discharging process instead of dissipation in NMOS network with SDCVSL, ADIABATIC LOGIC. It also increases the performance of circuits.

Here for this project, I am using MICRO WINDOW TOOL. By using this tool we can develop schematic for all above techniques and also find out the power dissipation.

Key words: Low power, CMOS, SDCVSL, Adiabatic logic.

I. INTRODUCTION:

Much of the research efforts of the past years in the area of digital electronics has been directed towards increasing the speed of digital systems. Recently, the requirement of portability and the moderate improvement in battery performance indicate that the power dissipation is one of the most critical design parameters.

The three most widely accepted metrics to measure the quality of a circuit or to compare various circuit styles are area, delay and power dissipation. Portability imposes a strict limitation on power dissipation while still demands high computational speeds. Hence, in recent VLSI systems the power-delay product becomes the most essential metric of performance. The reduction of the power dissipation and the improvement of the speed require optimizations at all levels of the design procedure. In this chapter, the proper circuit style and methodology is considered. Since, most digital Circuitry is composed of simple and/or complex gates, we study the best way to implement adders in order to achieve low power dissipation and high speed.

Several circuit design techniques are compared in order to find their efficiency in terms of speed and power dissipation. A review of the existing CMOS circuit design styles is given, describing their advantages and their limitations. Furthermore, a four-bit ripple carry adder for use as a benchmark circuit

was designed in a full-custom manner by using the different design styles, and detailed transistor-level simulations using HSPICE [2] were performed. Also, various designs and implementations of four multipliers are analysed in the terms of delay and power consumption. Two ways of power measurements are used.

In this chapter we study two different CMOS logic styles, they are

i. STATIC DIFFERENTIAL CASCODE
VOLTAGE SWITCH(SDCVSL)

ii. ADIABATIC LOGIC

Here we are comparing the parameters like power, delay and area of the above mentioned techniques with the CONVENTIONAL CMOS technique.

II. Power and Delay in Conventional CMOS Circuits:

Since the objective is to investigate the tradeoffs that are possible at the circuit level in order to reduce power dissipation while maintaining the overall system throughput, we must first study the parameters that affect the power dissipation and the speed of a circuit. It is well known that one of the major advantage of CMOS circuits over single polarity MOS circuits, is that the static power dissipation is very small and limited to leakage.

However, in some cases such as bias circuitry and pseudo-nMOS logic, static power is dissipated. Considering that in CMOS circuits the leakage current between the diffusion regions and the substrate is negligible, the two major sources of power dissipation are the switching and the short-circuit power dissipation

$$P = p_f C_L V_{dd}^2 f + I_{sc} V_{dd},$$

Where p_f is the node transition activity factor, C_L is the load capacitance, V_{dd} is the supply voltage, f is the switching frequency, I_{sc} is the current which arises when a direct path from power supply to ground is caused, for a short period of time during low to high or high to low node transitions. The switching component of power arises when energy is drawn from the power supply to charge parasitic capacitors. It is the dominant power component in a well designed circuit and it can be lowered by reducing one or more of p_f , C_L , V_{dd} and f , while retaining the required speed and functionality.

Even though the exact analysis of circuit delay is quite complex, a simple first-order derivation can be used in order to show its dependency of the circuit parameters

$$T_d \propto \frac{C_L V_{dd}}{K (V_{dd} - V_{th})^\alpha},$$

where K depends on the transistors aspects, V_{TH} is the transistor threshold voltage index which varies between 1 and 2 (α)

III. Static Differential Cascode Voltage Switch :

Static DCVSL is a differential style of logic requiring both true and complementary signals to be routed to gates. Figure 5.4 shows the circuit diagram of the static DCVSL full adder. Two complementary NMOSFET switching trees are constructed to a pair of cross-coupled PMOSFET transistors.

Depending on the differential inputs one of the outputs is pulled down by the corresponding NMOSFET network. The differential output is then latched by the cross-coupled PMOSFET transistors. Since the inputs drive only the NMOSFET transistors of the switching trees, the input capacitance is typically two or three times smaller than that of the conventional static CMOS logic.

SDCVSL CARRY

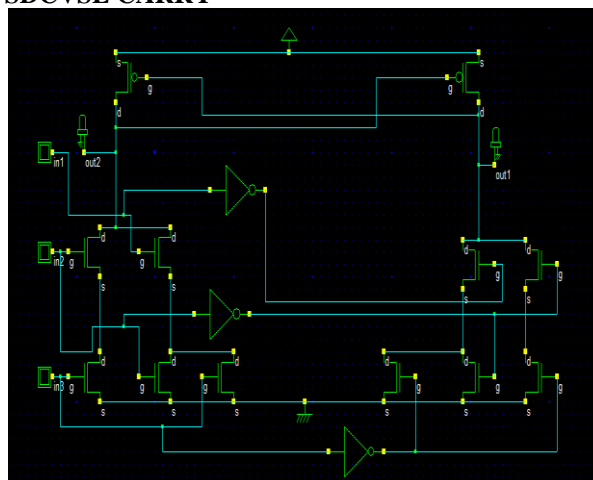

This carry circuit of SDCVSL circuit consists of 12 transistors with 3 inputs.

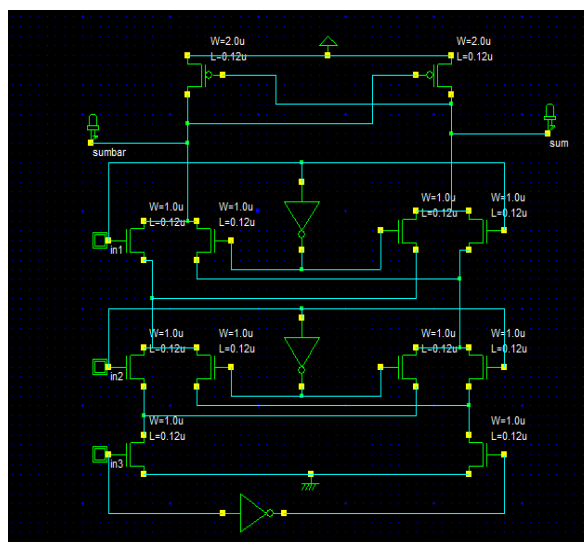

SDCVSL SUM

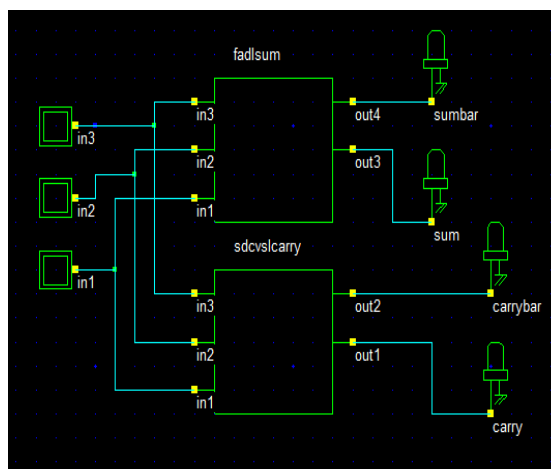

SDCVSL FULL ADDER

consuming less power and reducing power dissipation.

V. CONCLUSION

In this chapter, the most common kinds of adders have been characterized in terms of power, using either a traditional low-level design flow paradigm, which is rather tedious and incompatible with modern design flows, but provides the most accurate results, or a high-level design flow paradigm, which is commonly used.

In this paper we compared the performance of SDCVSL and adiabatic logic adder circuits with traditional CMOS adder circuits. The analysis shows that designs based on adiabatic principle gives superior performance when compared to traditional approaches in terms of power even though their transistor count is high in some circuits so for low power and ultra low power requirements adiabatic logic is an effective alternative for traditional CMOS logic circuit design.

A four-bit ripple carry adder was designed using adiabatic logic here is used as the benchmark circuit. All the circuits have been designed in a full-custom manner.

REFERENCES

- [1] A. Chandrakasan, R. Brodersen, *Low Power Digital Design*, Kluwer Academic Publishers, 1995.
- [2] Meta-Software, *HSPICE User's Manual - Version 96.1*, 1996.
- [3] K. Yano, Y. Sasaki, K. Rikino, K. Seki, "Top-Down Pass-Transistor Logic Design". *IEEE Journal of Solid-State Circuits*, vol.31, pp. 792-803. 1996
- [4] MIPS Technologies, "R4200 Microprocessor Product Information", MIPS Technologies Inc., 1994
- [5] R K. Navi, Md.Reza Saatchi and O. Daei, (2009) "A High-Speed Hybrid Full Adder," *European Journal of Scientific Research*, Vol 26 No.1, pp 29-33.
- [6] D. Sourdís, C. Piguet and C. Goutis, (2002) "Designing CMOS Circuits for Low Power, European Low-Power Initiative for Electronic System Design", Reading pp 71-96, Kluwer Academic Publishers.